

Spring Washers.

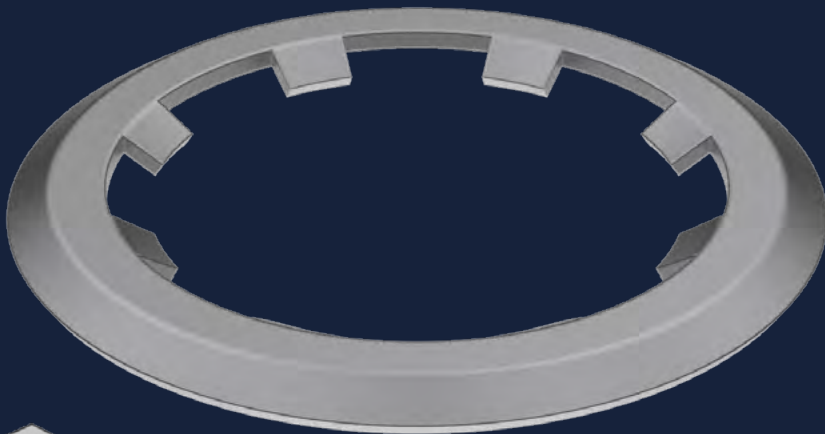

Tensioning Washers. | DSW, DSW-S

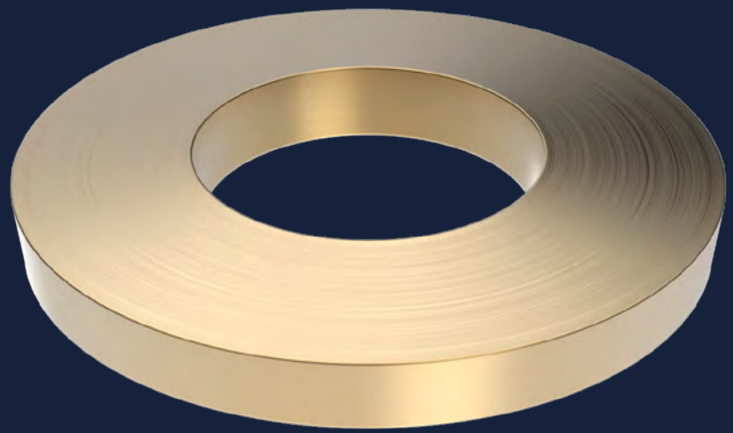
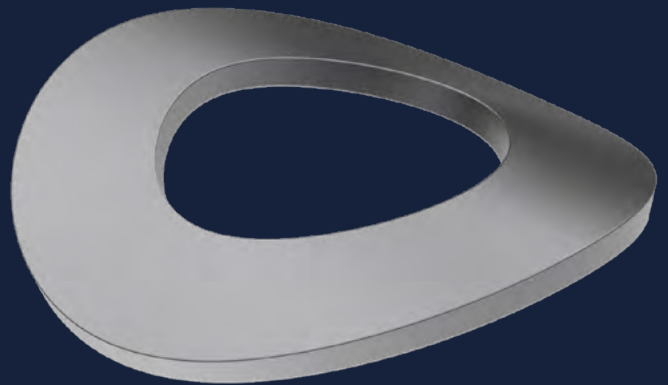
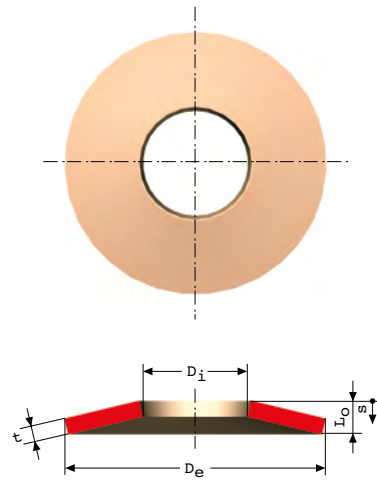
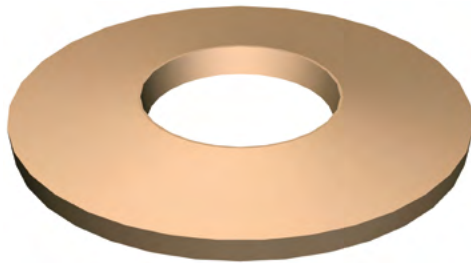
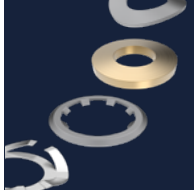

Heavy duty lock washer

Compliant with DIN 6796, our tensioning washers are robustly dimensioned and designed for use in medium or high load screw joints. The high spring force affords effective protection against relaxation and creep when joints are exposed to high stresses and movements resulting from thermal expansion or contraction. In such instances, tensioning washers replace conventional lock washers.

Tensioning washers can be stacked in series and/or parallel. Series stacking increases the available deflection of the spring stack and parallel stacking increases the force. The desired installation is as near flat as possible.

Bespoke range

If required, untreated spring washers can also be supplied direct from the factory. Spring washers in custom sizes and special materials, e.g. stainless, acid proof, phosphor bronze, Alloy 718 or Alloy 90, can be produced upon request.

Stainless steel range

New range of tensioning spring washers according to DIN 6796. We are using material EN 1.4568 (X 7 CrNiAl 17-7 / SS 2388) instead of regular stainless spring steel in order to:

- Achieve better fatigue properties
- Retain spring properties for a longer time
- Resist high operating temperature (up to 350 °C)

Our range consists of 6 dimensions, detailed information on page 130.

All dimensions are in mm

D_i = Inner diameter, tolerance H14

D_e = Outer diameter, tolerance h14

t = Material thickness

h_{max} = max free height in delivery condition

h_{min} = min dimension after setting test acc to DIN 267-26

Min residual spring force = after load with the contact force and release through a travel of 20 μ m

Contact force = forces for the setting test, acc to DIN267-26

Standard steel range

Material: EN 10132-4

Finish: Mechanically galvanised and yellow chromated

Working temperature: max 120 °C

Stainless steel range

Material: EN 1.4568 (X 7 CrNiAl 17-7 / SS 2388)

Working temperature: max 350 °C

1 kp = 9.80665 Newtons, 1 Newton = 0.10197 kp

Tensioning Washers. | DSW, DSW-S

Standard range (EN 10132-4)								
Size	Di	De	t	h max	h min	Min residual spring force	Contact force	Cat.no
M2	2,2	5	0,4	0,6	0,5	-	920	4664
M2,5	2,7	6	0,5	0,72	0,6	-	1540	4665
M3	3,2	7	0,6	0,85	0,7	-	2350	4666
M4	4,3	9	1	1,3	1,1	1400	4400	4668
M5	5,3	11	1,2	1,55	1,3	2300	7200	4669
M6	6,4	14	1,5	2	1,7	4200	10200	4670
M8	8,4	18	2	2,6	2,2	7700	18600	4672
M10	10,5	23	2,5	3,2	2,8	12400	29600	4673
M12	13	29	3	3,95	3,4	18000	43000	4674
M16	17	39	4	5,25	4,6	34000	80900	4675
M18	19	42	4,5	5,8	5,1	57000	102000	4676
M20	21	45	5	6,4	5,6	73000	130000	4677
M24	25	56	6	7,75	6,8	122000	188000	4678
M27	28	60	6,5	8,35	7,3	161000	246000	4679
M30	31	70	7	9,2	8	196000	300000	4680

Stainless steel range (EN 1.4568)								
Size	Di	De	t	h max	h min	Min residual spring force	Contact force	Cat.no
M4	4,3	9	1	1,3	1,1	1400	4400	S4668
M5	5,3	11	1,2	1,55	1,3	2300	7200	S4669
M6	6,4	14	1,5	2	1,7	4200	10200	S4670
M8	8,4	18	2	2,6	2,2	7700	18600	S4672
M10	10,5	23	2,5	3,2	2,8	12400	29600	S4673
M12	13	29	3	3,95	3,1	18000	43000	S4674

Lock Washers. | WLA, WLB

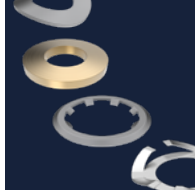

Aranlock lock washers are ideal for use as locking devices on shafts and tubes, etc. The lock washer has radial tabs with reinforcements on the edges, which increases the locking capacity and can be used on most materials, such as steel, metals or plastic.

In many cases, Aranlock can replace nuts, pins or other similar locking devices. Normally, no preparation of the shaft, such as grooves, is necessary, as the locking mechanism is very effective on its own. Fitting is simple and fast. The washer sits firmly and can only be removed by being broken.

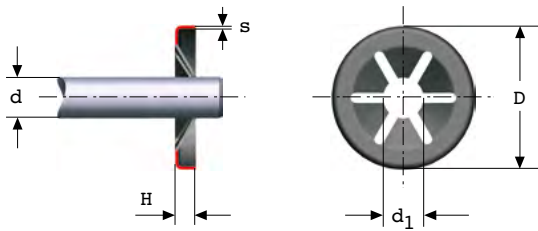

TYPE A

Lock washer for general use.

Material: CK 67

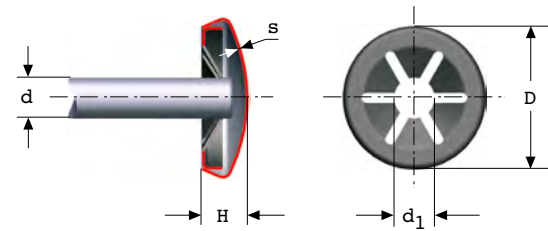

TYPE B

Lock washer with nickel-plated cup. Ideal for use as a stop on a shaft.

Material: CK 67

d	D $\pm 0,20$	d ₁	H $\pm 0,15$	S	No. slits	Cat.no
2	9,5	1,50-1,65	1,2	0,2	4	4814
2,5	6,5	2,00-2,15	1,2	0,2	4	4815
3	9,5	2,50-2,650	1,2	0,2	4	4816
2	11,3	1,50-1,65	1,5	0,2	5	4817
3	11,3	2,70-2,80	1,5	0,2	6	4818
4	11,3	3,50-3,65	1,2	0,2	6	4819
5	11,3	4,50-4,65	1,2	0,2	6	4820
4	15	3,50-3,65	1,5	0,3	6	4821
5	15	4,50-4,65	1,5	0,3	6	4822
6	15	5,50-5,65	1,5	0,3	6	4823
7	15	6,50-6,65	1,5	0,3	6	4824
8	15	7,50-7,65	1,5	0,3	6	4825
8	18	7,50-7,65	1,6	0,3	6	4826
9	18	8,50-8,65	1,6	0,3	6	4827
10	18	9,50-9,65	1,6	0,3	6	4828
8	21	7,50-7,65	2,1	0,3	6	4830
9	21	8,50-8,65	2,1	0,3	6	4832
10	21	9,50-9,65	2,1	0,3	6	4834
11	21	10,50-10,65	2,1	0,3	6	4835
12	21	11,50-11,65	2,1	0,3	6	4836
18	36,5	17,30-17,45	3,2	0,4	9	4837

d	D $\pm 0,5$	d ₁	H $\pm 0,2$	S	No. slits	Cat.no
2	10	1,50-1,65	3,8	0,3	4	4838
2,5	7,5	2,00-2,15	3,0	0,3	4	4839
3	10	2,50-2,65	3,8	0,3	4	4840
2	12	1,50-1,65	4,5	0,3	5	4841
3	12	2,50-2,65	4,5	0,3	6	4842
4	12	3,50-3,65	4,5	0,3	6	4844
5	12	4,50-4,65	4,5	0,3	6	4845
4	16	3,50-3,65	6,0	0,3	6	4846
5	16	4,50-4,65	6,0	0,3	6	4847
6	16	5,50-5,65	6,0	0,3	6	4848
7	16	6,50-6,65	6,0	0,3	6	4849
8	16	7,50-7,65	5,7	0,3	6	4850
8	19	7,50-7,65	6,5	0,3	6	4851
9	19	8,50-8,65	6,5	0,3	6	5066
10	19	9,50-9,65	6,5	0,3	6	5067
8	22	7,50-7,65	7,0	0,3	6	5068
9	22	8,50-8,65	7,0	0,3	6	5069
10	22	9,50-9,65	7,0	0,3	6	5070
11	22	10,50-10,65	7,0	0,3	6	5071
12	22	11,50-11,65	7,0	0,3	6	5072

Lock Washers. | WLC

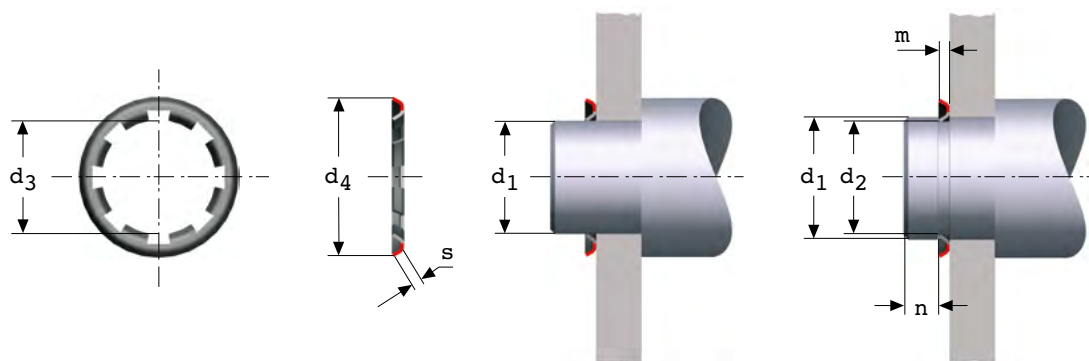

TYPE C

Locking washer with decreased outer diameter and extra high locking force. By providing the shaft with a groove, the locking force can be increased by up to 75%.

Material: CK 67

d1 h12	d ₂	d ₃	d ₄	s	m	n	No. teeth	Allowed load without groove, kp	Cat. no
2	1,9	1,8	6,5	0,25	0,4	1	3	20	5073
3	2,9	2,8	8	0,25	0,4	1	4	25	5074
4	3,9	3,8	9	0,25	0,4	1	4	25	5075
5	4,9	4,8	10	0,25	0,4	1	4	25	5076
6	5,9	5,75	11	0,25	0,5	1,5	5	25	5077
7	6,9	6,75	12	0,25	0,5	1,5	5	25	5078
8	7,85	7,75	13	0,25	0,5	1,5	5	25	5079
10	9,85	9,7	16	0,30	0,6	1,5	5	40	5080
12	11,85	11,7	18	0,30	0,6	1,5	6	40	5081
14	13,8	13,65	20,5	0,30	0,6	1,5	6	50	5082
15	14,6	14,4	23	0,50	0,8	2	8	80	5083
16	15,8	15,6	24,5	0,40	0,8	2	7	90	5084
20	19,75	19,5	29	0,50	1	2	8	110	5085
22	21,75	21,5	31	0,50	1	2	8	120	5086
25	24,75	24,5	34	0,50	1	2	8	120	5087
30	29,7	29,5	40	0,50	1	2	8	140	5088

Wave Spring Washers. | WW

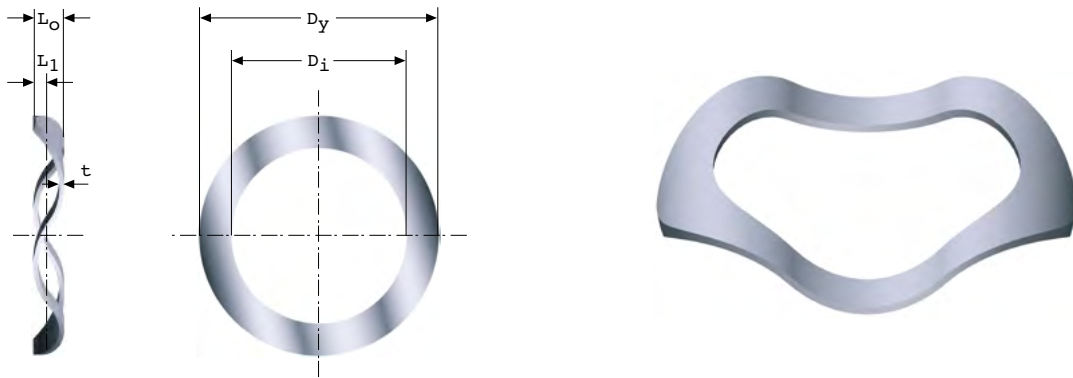
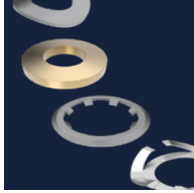

Imperial range

Wave spring washers have a restricted spring capacity and are primarily used to eliminate axial play, e.g. against a bearing. D_y 4.65–7.75 mm has two waves, others have three.

Diameter dimensions quoted are in mm and with the washer flat.

D_y = Outer diameter

D_i = Inner diameter

L_o = Unloaded length

t = Thickness

L_l = Loaded length

F_n = Spring force in Newtons at L_l

Material: % Stainless spring steel
EN 10270-3-1.4310,
Other CK 67

Finish: Untreated

1 kp = 9.80665 Newtons, 1 Newton = 0.10197 kp

D_y	D_i	t	L_o	L_l	F_l	Cat. no
4,65	3,4	0,09	0,58	0,3	1–2	% 7435
6,15	4,92	0,14	0,76	0,38	2–4	% 7436
7,75	6,17	0,17	0,76	0,38	2–4	% 7437
9,32	6,73	0,15	0,76	0,38	9–18	% 7438
12,29	10,08	0,23	0,74	0,51	13–22	7439
12,5	8,89	0,18	0,89	0,51	13–22	% 7440
15,44	11,66	0,2	0,94	0,64	13–22	7441
15,7	11,18	0,2	1,02	0,64	13–22	% 7442
18,57	14,94	0,23	1,19	0,76	13–22	7443
18,64	13,49	0,23	1,27	0,76	18–31	% 7444
21,72	16,51	0,25	1,52	0,76	18–31	% 7445
23,5	18,26	0,25	1,68	0,84	27–40	% 7446
25,5	19,81	0,27	1,8	0,89	31–44	7447
27,43	21,31	0,29	1,85	0,91	36–53	7448
27,99	21,74	0,30	1,91	0,94	40–58	7449
29,44	22,89	0,33	2,03	1,02	44–62	7450
31,37	24,41	0,36	2,21	1,09	58–76	7451
34,32	26,7	0,38	2,51	1,24	71–89	7452
39,19	30,51	0,43	2,67	1,32	85–102	7453
39,19	30,51	0,51	3,18	1,57	120–156	7454
40,46	31,47	0,46	2,79	1,39	93–120	7455
41,17	32,03	0,47	2,84	1,42	98–125	7456
46,2	35,66	0,51	3,18	1,57	116–151	7457
51,51	40,01	0,56	3,56	1,75	138–174	7458
54,15	42,11	0,58	3,76	1,85	147–191	7459
61,47	47,55	0,64	4,27	2,08	178–223	7460
67,18	52,55	0,71	4,67	2,29	223–285	7461
71,53	55,88	0,76	5	2,47	254–325	7462
79,2	61,47	0,89	5,26	2,64	343–441	7463
84,53	66,12	0,91	5,77	2,84	352–450	7464
89,38	69,60	0,97	5,94	2,95	392–498	7465
99,49	77,39	1,07	6,55	3,25	467–601	7466
109,2	85,6	1,14	7,67	3,76	547–699	7467
117,5	91,74	1,19	8,49	4,11	623–792	7468
126,9	98,81	1,27	9,02	4,37	694–881	7469
137,3	106,8	1,35	9,86	4,75	770–983	7470
147,7	115	1,4	11,2	5,31	850–1081	7471
156,8	122	1,47	11,7	5,59	935–1193	7472
166,4	130	1,55	12,6	5,97	1019–1295	7473
176,4	137,36	1,6	13,6	6,43	1104–1406	7474
186	144	1,65	14,6	6,83	1193–1522	7475

Wave Spring Washers. | WW

Metric range

All dimensions quoted are in mm with washer flat

D_y = Outer diameter

D_i = Inner diameter

t = Thickness

L_0 = Unloaded length

n = number of waves

L_1 = Loaded length

F_1 = Spring force in Newtons at L_1

R = Rate

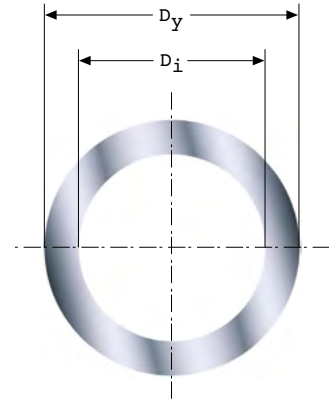
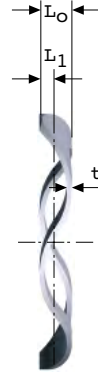

Material: CK 67

Finish: Untreated

1 kp = 9.80665 Newtons, 1 Newton = 0.10197 kp

D_y	D_i	t	L_0	n	L_1	F_1	R	Cat.no
9,5	4,5	0,15	1,5	2	1,0	15	30	4598
12,5	7,5	0,2	1,5	2	1,0	19	38	4604
15,5	10,5	0,15	1,5	3	1,0	19	38	4608
15,5	10,5	0,15	1,6	3	1,0	23	38	4613
16,5	11,5	0,2	1,5	3	1,0	29	58	4617
18,5	13	0,2	2	3	1,0	29	29	4618
20,5	15	0,2	2	3	1,0	29	29	4630
21,5	16	0,23	2	3	1,0	34	34	4631
21,5	16	0,2	1,8	4	1,0	35	44	4632
23,5	17	0,25	3	3	1,5	35	23	4633
25,5	19	0,25	3	3	1,5	39	26	4634
25,5	19	0,3	3	3	1,5	44	29	4635
25,5	19	0,43	2	4	1,5	88	176	4636
27,5	21	0,3	2,6	3	1,5	39	36	4637
27,5	21	0,3	3	3	1,5	54	36	4638
27,5	21	0,4	2	4	1,5	108	216	4639
29,5	23	0,3	3,5	3	1,5	44	22	4640
31,5	25	0,35	3,2	3	1,5	46	27	4641
31,5	25	0,35	3,5	3	1,5	54	27	4642
31,5	25	0,35	2,5	4	1,5	108	108	4643
31,5	25	0,35	4	3	1,5	67	27	4644
34,5	28	0,4	3,5	3	1,5	68	34	4645
34,5	28	0,4	2,5	4	1,5	137	137	4646
34,5	28	0,4	3,8	3	1,5	78	34	4647
36,5	30	0,38	4	3	1,5	55	22	4648
36,5	30	0,38	4,5	3	1,5	66	22	4649
37,5	31	0,4	4	3	1,5	73	29	4650
39,5	33	0,43	4	3	1,5	77	31	4651
39,5	33	0,43	3	4	1,5	147	98	4652
41,5	33,5	0,38	5	3	1,5	70	20	4653
41,5	33,5	0,38	3,5	4	1,5	176	88	4654
41,5	33,5	0,4	5	3	1,5	87	25	4655
43,5	35,5	0,4	5	3	1,5	77	22	4656
46,5	38,5	0,4	4,7	3	1,5	80	25	4657
46,5	38,5	0,45	4,4	3	1,5	87	30	5011
46,5	38,5	0,45	3,5	4	1,5	236	118	4681
46,5	38,5	0,45	5,2	3	1,5	112	30	4682

Wave Spring Washers. | WW

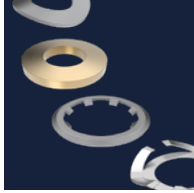

D _y	D _i	t	L _o	n	L ₁	F ₁	R	Cat.no
51,5	42	0,4	5	3	1,5	87	25	4683
51,5	42	0,45	5,5	3	1,5	112	28	4684
51,5	42	0,45	4	4	1,5	332	133	4685
54,5	43,5	0,45	5,5	3	1,5	132	33	4686
61,5	50,5	0,5	4	3	1,5	75	30	4687
61,5	50,5	0,5	5,2	3	1,5	111	30	4688
61,5	50,5	0,55	5,5	3	1,5	132	33	4689
61,5	50,5	0,55	4	4	1,5	392	157	4690
67,5	55	0,55	6,5	3	1,5	175	35	4691
69,5	57	0,55	6,5	3	1,5	155	31	4692
71,5	59	0,55	5,8	3	1,5	133	31	4693
71,5	59	0,55	6,5	3	1,5	155	31	4694
71,5	59	0,55	5,5	4	1,5	412	103	4695
74,5	62	0,6	7	3	1,5	203	37	4696
79,5	63,5	0,6	6,4	3	1,5	156	32	4707
79,5	63,5	0,6	7	3	1,5	176	32	4747
79,5	63,5	0,6	6	4	1,5	540	120	4748
84,5	67	0,6	8	3	1,5	201	31	4749
89,5	72	0,6	6,5	3	1,5	135	27	4795
89,5	72	0,6	8	3	1,5	175	27	4796
89,5	72	0,66	6,5	4	1,5	590	118	4797
89,5	72	0,6	10,5	3	1,5	243	27	4798
94,5	75,5	0,7	8,5	3	1,5	266	38	4799
99,5	80,5	0,7	8,5	3	1,5	203	29	4800
99,5	80,5	0,7	7	4	1,5	605	110	4801
104,5	84,5	0,7	8,5	3	1,5	266	38	4802
109,5	90,5	0,7	9,5	3	1,5	224	28	4803
109,5	90,5	0,76	7	4	1,5	687	125	4804
114,5	95,5	0,8	9,5	3	1,5	280	35	4805
116,5	97,5	0,8	9,5	3	1,5	248	31	4806
119,5	100,5	0,8	9,5	3	1,5	248	31	4807
124,5	105,5	0,8	9,5	3	1,5	312	39	4833
126,5	107,5	0,8	9,5	3	1,5	312	39	4854
129,5	110,5	0,8	9,5	3	1,5	264	33	4858
129,5	110,5	1	7,5	4	1,5	906	151	4860
129,5	110,5	0,8	11,5	3	1,5	330	33	4871
134,5	114	0,9	11	3	1,5	361	38	4969
136,5	116	0,9	11	3	1,5	285	30	4970
139,5	119	0,9	11	3	1,5	285	30	4971
139,5	119	0,9	9	4	1,5	495	66	4972
144,5	124	0,9	11	3	1,5	418	44	4973
149,5	129	1	11	3	1,5	266	28	4974
149,5	129	1	9	4	1,5	547	73	4975
156,5	136	1	12	3	1,5	336	32	4976
159,5	139	1	12	3	1,5	336	32	4977
159,5	139	1	10	4	1,5	501	59	4978
169,5	149	1,2	12	3	3,5	297	35	4979
169,5	149	1,2	10	4	3,5	546	84	4980
179,5	159	1,2	12	3	3,5	314	37	4981
179,5	159	1,2	10	4	3,5	455	70	4982
189,5	167	1,2	12	3	3,5	331	39	4983
189,5	167	1,2	10	4	3,5	422	65	4984
199,5	177	1,2	12	3	3,5	170	20	4985
209,5	185,5	1,2	12,5	3	3,5	171	19	4986
214,5	190,5	1,2	12,5	3	3,5	171	19	4987
219,5	195,5	1,6	12,5	3	3,5	333	37	4988
224,5	200,5	1,6	12,5	3	3,5	567	63	4989
229,5	205	1,8	12,5	3	3,5	540	60	4990
239,5	214	1,8	14,5	3	3,5	594	54	4991
249,5	224	2	14,5	3	3,5	803	73	4992
259,5	234	2,3	14,5	3	3,5	770	70	4993
269,5	242	2,6	15	3	3,5	1184	103	4994
279,5	252	2,6	15	3	3,5	897	78	4995

Finger Spring Washers. | WF

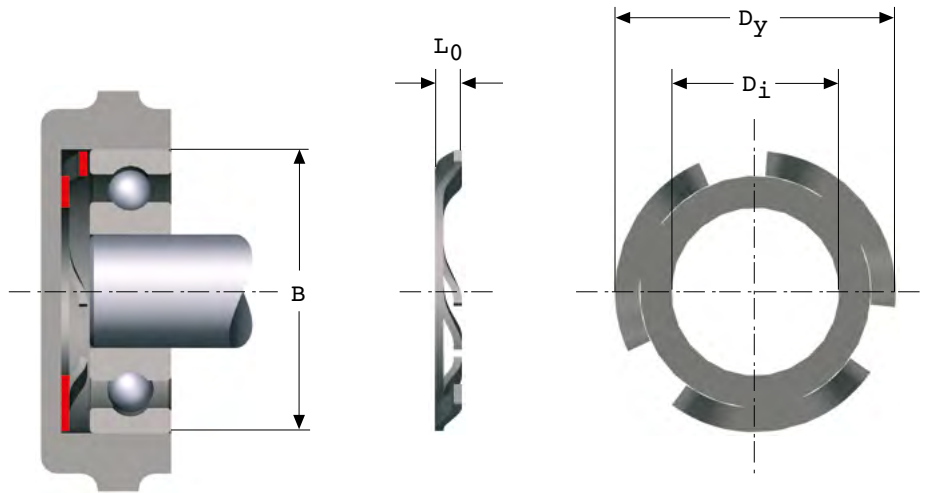

Finger spring washers are used to dampen noise and vibration. They are particularly suitable for high speed applications and are also frequently used to eliminate play and axial wear. Washers with a D_y of 15.11 mm have three fingers, others have six.

All dimensions are in mm

D_y = Outer diameter

D_i = Inner diameter

L_o = Unloaded length

L_l = Loaded length

F_1 = Spring force in Newtons at L_l

B = Outer diameter of bearing

Material: Spring steel CK 67

Finish: Untreated

1 kp = 9.80665 Newtons, 1 Newton = 0.10197 kp

D_y	D_i	L_o	L_l	F_1	B	Cat. no
15,11	7,92	2,38	1,57	1,4–4,4	16	7476
18,49	8,74	3,18	1,57	18–36	19	7477
21,49	8,74	3,18	1,57	13–31	22	7478
21,49	11,51	3,18	1,57	40–58	22	7479
23,52	11,51	3,18	1,57	27–45	24	7480
23,52	8,74	3,18	1,57	98–125	24	7481
25,5	13,11	3,18	1,57	22–40	26	7482
25,5	13,11	3,18	1,57	36–53	26	7483
29,57	10,31	3,18	1,57	67–93	30	7485
29,57	17,48	3,18	1,57	267–334	30	7486
29,57	17,48	3,18	1,57	45–62	32	7487
31,5	14,3	3,18	1,57	67–93	32	7488
31,5	17,48	3,18	1,57	67–93	32	7489
34,54	20,68	3,18	1,57	49–67	35	7490
34,54	20,68	3,18	1,57	76–111	35	7491
39,5	24,66	3,18	1,57	67–93	40	7492
39,5	25,4	3,18	1,57	138–174	40	7493
46,48	30,2	3,18	1,57	76–102	47	7494
51,35	34,52	3,18	1,57	76–102	52	7495

Curved Spring Washers. | WCS, DIN 137

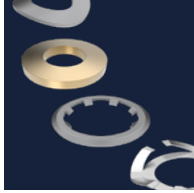

Curved spring washers are primarily used in screwed joint reinforcements where a lower locking force is required. These washers can also be used to eliminate axial play. Type A is recommended for screws with rounded heads and type B for screws with hexagon heads.

All dimensions are in mm

D_i = Inner diameter

D_y = Outer diameter

t = Material thickness

h = Unloaded length

Material: Spring steel CK 67

Finish: Untreated

TYPE A

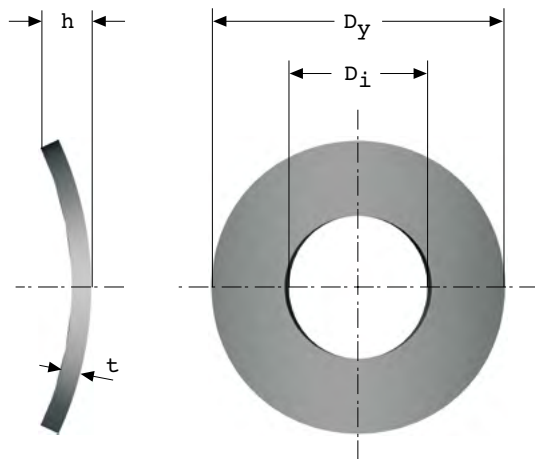

TYPE B

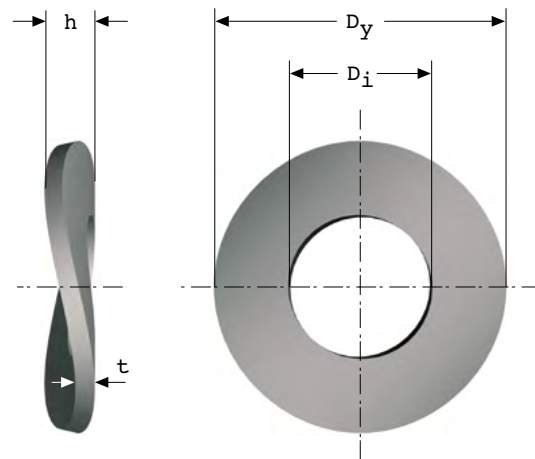

Bolt [D_i H14	D_y js16	t	h min.	h max	Cat. no
2	2,2	4,5	0,3	0,5	1	862
2,3	2,5	5	0,3	0,5	1	863
2,6	2,8	5,5	0,3	0,55	1,1	864
3	3,2	6	0,4	0,65	1,3	865
3,5	3,7	7	0,4	0,7	1,4	866
4	4,3	8	0,5	0,8	1,6	867
5	5,3	10	0,5	0,9	1,8	868
6	6,4	11	0,5	1,1	2,2	869
7	7,4	12	0,5	1,4	2,6	870
8	8,4	15	0,5	1,7	3,4	871
10	10,5	18	0,8	2	4	872
12	13	24	1,2	2,5	4,5	873
16	16,5	30	1,5	3	5	874

Bolt [D_i H14	D_y js16	t	h min.	h max	Cat. no
4	4,3	9	0,5	1	2	875
5	5,3	11	0,5	1,1	2,2	876
6	6,4	12	0,5	1,3	2,6	877
8	8,4	15	0,8	1,5	3	878
10	10,5	21	1	2,1	4,2	879
12	13	24	1,2	2,5	5	880
14	15	28	1,6	3	6	881
16	17	30	1,6	3,2	6,4	882