

PC SERIES

Accelerate® Tooling Collection | Dimensions

PC Parallel Clamps

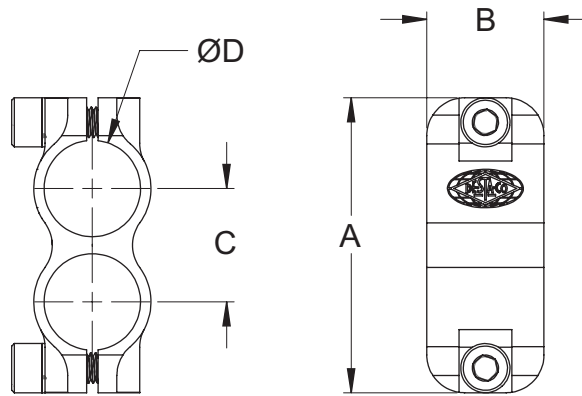

Model Number	A	B	C	ØD	Material	Weight
PC-10E-10E-A	[3.07] 78	[1.22] 31	[1.18] 30	[1.00] 25.4	Aluminum	[0.21 lb] 95g
PC-20M-20M-A	[2.72] 69	[1.02] 26	[0.91] 23	[0.79] 20	Aluminum	[0.18 lb] 83g
PC-20M-20M-S	[2.72] 69	[1.02] 26	[0.91] 23	[0.79] 20	Steel	[0.39 lb] 177g
PC-25M-25M-A	[3.07] 78	[1.22] 31	[1.18] 30	[1.00] 25.4	Aluminum	[0.21 lb] 93g
PC-30M-30M-A	[3.86] 98	[1.50] 38	[1.34] 34	[1.18] 30	Aluminum	[0.34 lb] 155g
PC-30M-30M-S	[3.86] 98	[1.50] 38	[1.34] 34	[1.18] 30	Steel	[0.83 lb] 378g

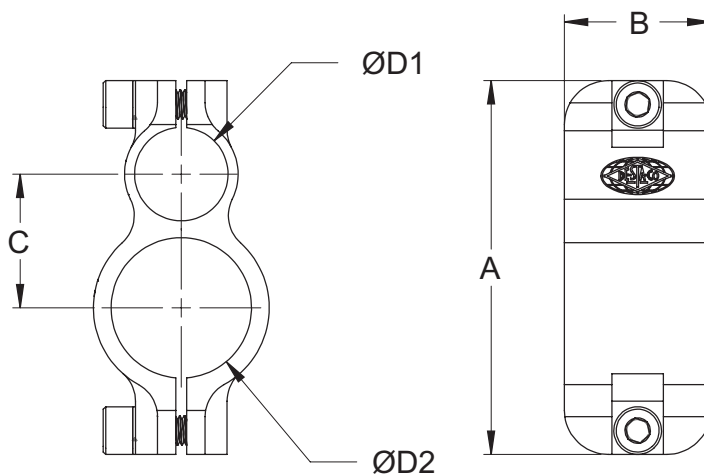

Model Number	A	B	C	ØD1	ØD2	Weight
PC-15E-10E-A	[4.02] 102	[1.57] 40	[1.44] 36.5	[1.00] 25.4	[1.50] 38.1	169g [0.37 lb]
PC-30M-20M-A	[3.29] 83.5	[1.5] 38	[1.12] 28.5	[0.79] 20	[1.18] 30	129g [0.28 lb]
PC-30M-25M-A	[3.52] 89.5	[1.5] 38	[1.24] 31.5	[0.98] 25	[1.18] 30	136g [0.30 lb]
PC-40M-25M-A	[4.02] 102	[1.57] 40	[1.44] 36.5	[0.98] 25	[1.57] 40	158g [0.35 lb]